



MAGNESIUM ANODES

SOIL AND WATER APPLICATION

CP Tech standard magnesium anodes are manufactured typically to Australian Standard AS 2239-1993 or equivalent. Other anode alloys are available, to suit customer's requirements.

Standard magnesium anode specifications (compositions are % by weight):

Specification Code	High Purity (Designation M3)	High Potential (Designation M1)
Cu	0.05 maximum	0.02 maximum
Al	5.3 - 6.7	0.01 maximum
Si	0.05 maximum	-
Fe	0.03 maximum	0.03 maximum
Mn	0.25 - 0.40	0.5 - 1.3
Ni	0.003 maximum	0.001 maximum
Zn	2.5 - 3.5	-
Others each	-	0.05 maximum
Others total	0.30 maximum	0.30 maximum
Mg	Remainder	Remainder
Efficiency	50%	50%
Potential	1.50 volts Ag/AgCl ref.	1.70 volts Ag/AgCl ref.
Capacity (amp hours)	1230 per kg	1230 per kg

Magnesium anodes are a frequent feature of fresh water tanks and condensers. These can be manufactured in a variety of shapes and sizes, according to a customer's specific requirements.

Cathodic Protection Technology Pte Ltd

No. 4 Tuas Drive 1 Singapore 638671 Tel: (65) 68623551 Fax: (65) 68616436

Email: cptech@singnet.com.sg

<http://www.cptech.net>

MAGNESIUM PIPELINE ANODE

Magnesium anodes are usually supplied with a PVC insulated / PVC sheathed copper cable. The anodes can be supplied bare or with rapid wetting backfill, of the following composition.

Powdered Gypsum	75%
Granular Bentonite	20%
Sodium Sulphate	5%

The anode and backfill, if supplied together, are contained in a cotton bag.

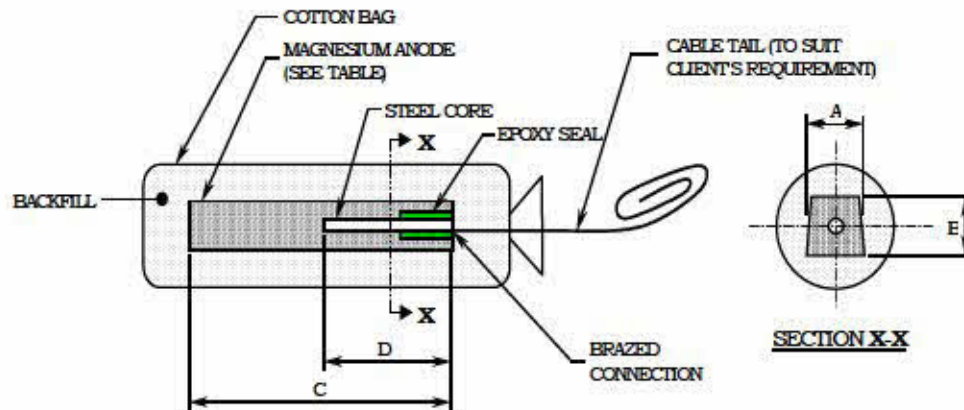

Some typical sizes (other sizes available upon request):

Anode Type	A (mm)	B (mm)	C (mm)	D (mm)	Magnesium weight (kg)
23 M1 23 M3	89	92	203	127	2.3
41 M1 41 M3	95	95	300	230	4.1
77 M1 77 M3	110	110	425	330	7.7
100 M1 100 M3	110	110	550	362	10.0
145 M1 145 M3	125	125	520	362	14.5
232 M1 232 M3	150	150	615	362	23.2